

# **Chapter 07**

## **Lifting and Shoring**

## TABLE OF CONTENTS

Chapter	Title	
<b>07-10-00</b>	<b>JACKING</b> .....	<b>3</b>
07-10-01	Balance Weight .....	3
<b>07-20-00</b>	<b>SHORING</b> .....	<b>4</b>
07-20-01	Shoring the Front .....	4
07-20-02	Shoring the Tail .....	5

## 07-10-00

## JACKING

### 07-10-01

### Balance Weight

Prior to the removal of the horizontal and/or vertical stabilizer(s) or prior to shoring the aircraft as described in Chapter 07-20-00 it is necessary to weight the tail to prevent aircraft from tilting onto the nose. In this case follow the steps described below (refer to Figure 1):

- 1 Put a weight (1) of min. 30 kg under the tail.
- 2 Remove the RH tail side skin and the tail cone access panel per Chapter 51.
- 3 Connect the weight with the now accessible steel tube (3) by means of a strap (2). Prevent damage of paint and control cables.

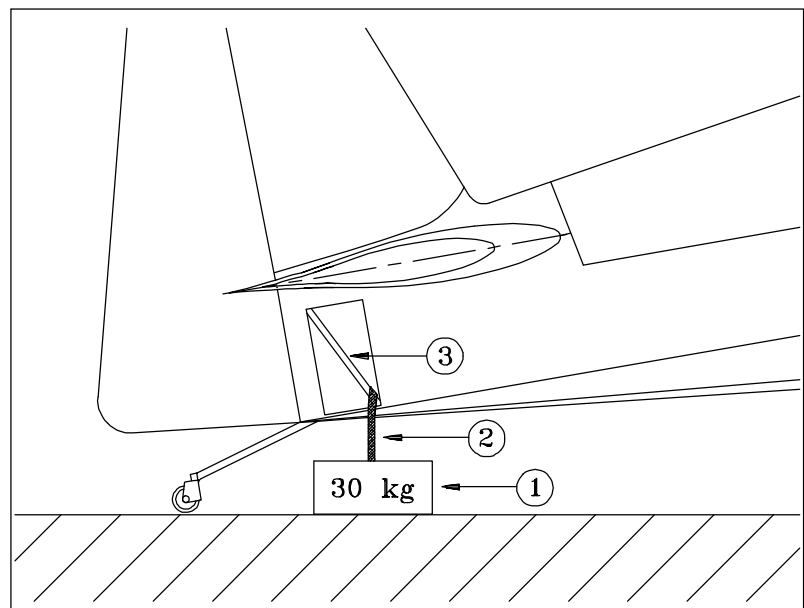

*Balance Weight  
Figure 1*

## 07-20-00

## SHORING

Shoring the Extra 300L is necessary, when the main landing gear or the tail wheel has to be removed or installed.

### 07-20-01

### Shoring the Front

- 1 Remove the fore access panels up to aft the main landing gear as per Chapter 51-00-01.
- 2 Install a balance weight (3, Figure) at the tail as per Chapter 07-10-01.
- 3 Hoist the aircraft by means of both engine hoisting points (1).

#### CAUTION

**Prevent damage of ventilation tubing, brake lines and drains, when shoring the aircraft.**

- 4 Shore the aircraft by means of two supports (2), which are to put under the left and right bottom longeron each in the area behind the landing gear as shown in Figure 2. This is possible also, when the landing gear is installed.

#### WARNING

**Maintain hoisting strap as a security device to prevent nose over of the aircraft during maintenance work.**

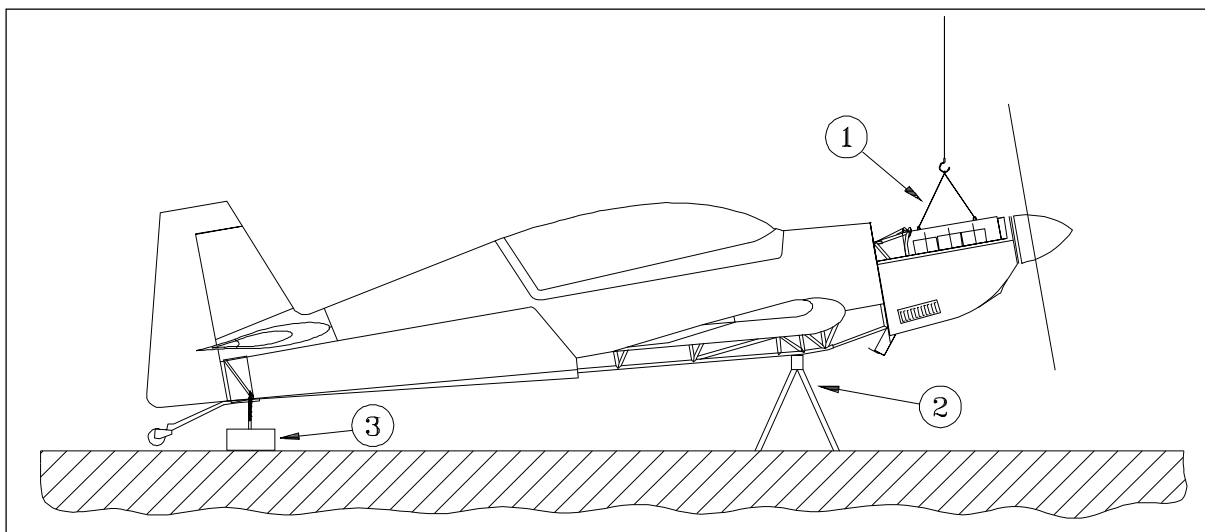

*Shoring the Front  
Figure 2*

## 07-20-02

## Shoring the Tail

Refer to Figure 3.

- 1 Secure the main wheels with wheel chocks.
- 2 Make available two ca. 2.5 feet high, ca. 1 foot wide and ca. 3 feet long supports.
- 3 Cushion the supports.

### CAUTION

**Don't handle the elevator when lifting the tail.**

### WARNING

**Do not lift the tail higher than necessary for supporting. The aircraft may tilt onto the nose.**

- 4 Lift the tail some centimeters by handling carefully the horizontal fins and put the cushioned supports under each side of the horizontal stabilizer.

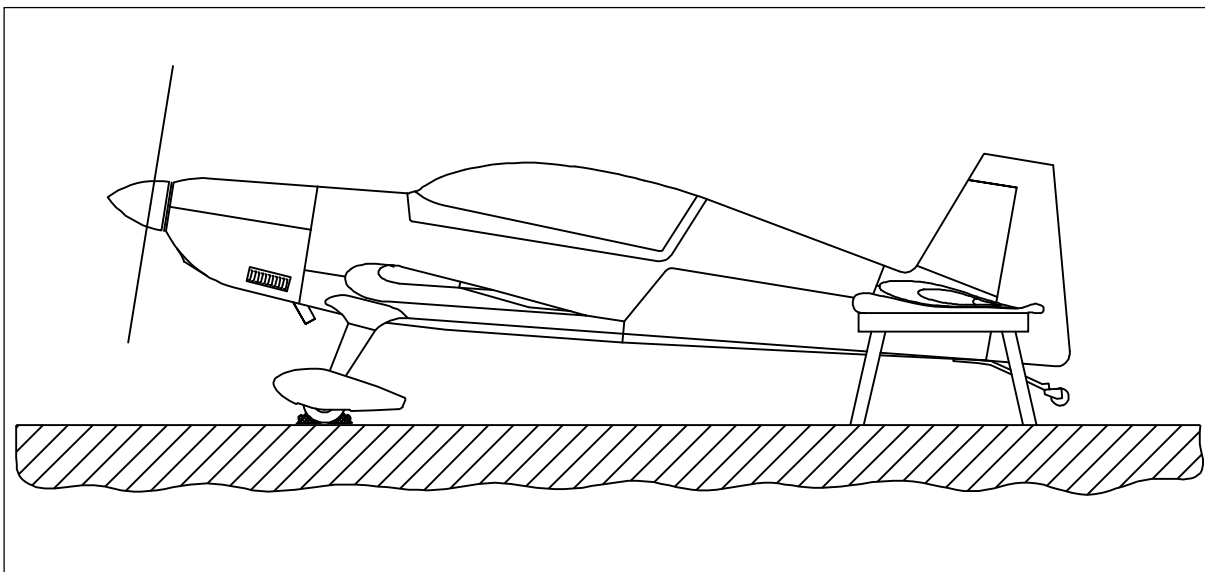

*Shoring the Tail*  
*Figure 3*