

# **Chapter 08**

## **Leveling and Weighing**

## TABLE OF CONTENTS

Chapter	Title	
<b>08-00-00</b>	<b>GENERAL</b> .....	<b>3</b>
<b>08-10-00</b>	<b>WEIGHING</b> .....	<b>4</b>
<b>08-20-00</b>	<b>LEVELING</b> .....	<b>7</b>

## 08-00-00

## GENERAL

This chapter contains all information and procedures that are necessary for weighing and leveling the EXTRA 300L and for determining the Center of Gravity.

Weigh the aircraft and determine the Center of Gravity each 5 years, after installation of additional equipment or after repairs.

### **I M P O R T A N T**

**Weigh, read the scales and calculate with carefulness. Incorrect weighing or determination of Center of Gravity endanger the pilot and the aircraft.**

**08-10-00**

## **WEIGHING AND CALCULATION OF C OF G**

---

### **N O T E**

---

**Weigh the aircraft only on even floor and in closed halls (wind protected). Use three identical scales.**

- 1 Ensure that the aircraft is fully equipped with equipment in locations according to the equipment list (PILOT'S OPERATING HANDBOOK & FLIGHT MANUAL (POH&FM), Section 6.6).
- 2 Defuel the aircraft (wing tanks, center and acro tank) to the unusable fuel level.
- 3 Replenish engine oil to the minimum sump capacity for acrobatic flight (refer to POH&FM Section 1.7)
- 4 Remove foreign objects (e.g. tools, luggage).
- 5 Clean and dry the aircraft.
- 6 Put the rear seat to middle position and close canopy.
- 7 Weigh two of those wheel chocks that will be used for securing the main wheels. Enter the weight below in Page 5 "Tare weight scale 1/2 (chocks)".
- 8 Weigh the jack that will be used for jacking the tail wheel. Enter the weight below in Page 5 "Tare weight scale 3 (jack)".
- 9 Roll the main wheels onto the scales 1 and 2.
- 10 Level the aircraft as per ch. 08-20-00.
- 11 Put the control surfaces to neutral position.
- 12 Drop perpendiculars from the underside of the fire wall, the centers of the main wheels and the tail wheel and mark on the floor to get the arms  $X_1$  and  $X_2$  (see Page 6).
- 13 Enter the arms on page 6.
- 14 Read the scales and enter the weights below. Calculate the net weights and transfer the values to Page 6.

15 Calculate C of G using the formula given below  
(Page 6).

Gross weight scale 1                   ..... kg

Tare weight scale 1 (chocks) -. . . . . kg

Net weight scale 1 ( $W_1$ )               ..... kg

Gross weight scale 2                   ..... kg

Tare weight scale 2 (chocks) -. . . . . kg

Net weight scale 2 ( $W_2$ )               ..... kg

Gross weight scale 3                   ..... kg

Tare weight scale 3 (jack)           -. . . . . kg

Net weight scale 3 ( $W_3$ )               ..... kg

## Empty Weight and Center of Gravity Position EXTRA 300L

Data according to "TC Data-Sheet" and "Pilot's Operating Handbook and LBA approved Airplane Flight Manual" Doc.-No.: EA - 06701

Equipment according to Equipment List dated: .....

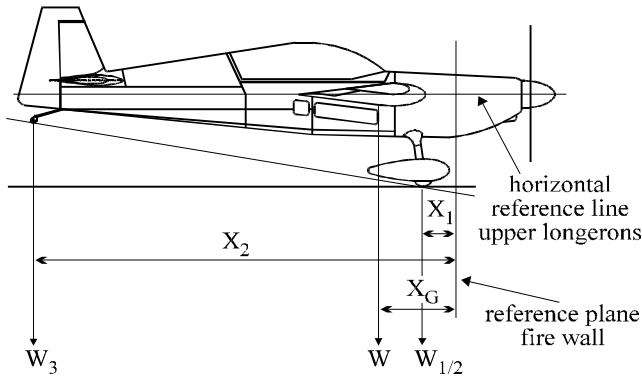

Legend:

- $X_1$  = Arm: fire wall - main wheels
- $X_2$  = Arm: fire wall - tail wheel
- $X_G$  = Arm: fire wall - Center of Gravity
- $W_1$  = Net weight main wheel LH
- $W_2$  = Net weight main wheel RH
- $W_3$  = Net weight tail wheel
- $W$  = Empty weight

$$X_G = \frac{W_1 \cdot X_1 + W_2 \cdot X_1 + W_3 \cdot X_2}{W}$$

$$W = W_1 + W_2 + W_3$$

Item	Weight	Arm	Moment
Main wheel LH	( $W_1$ ) ..... kg	( $X_1$ ) ..... cm	= ..... kgcm
Main wheel RH	( $W_2$ ) ..... kg	( $X_1$ ) ..... cm	= ..... kgcm
Tail wheel	( $W_3$ ) ..... kg	( $X_2$ ) ..... cm	= ..... kgcm
<b>Empty weight</b>	( $W$ ) ..... kg	<b>Total moment</b> .....	..... kgcm

$$\frac{\text{Total moment}}{\text{Empty weight}} = X_G$$

**Empty weight** is ( $W$ ) ..... kg\*.

- $W_{\min}$  : 640kg
- $W_{\max}$  : 665kg (acro II)
- $W_{\max}$  : 701kg (acro I)
- $W_{\max}$  : 745kg (Normal Cat.)

**Center of Gravity** is ( $X_G$ ) ..... cm aft fire wall.

Weighing performed by: .....

Aircraft Inspector: .....

Sign: .....

\* If value exceeds the given tolerances, contact the manufacturer.

## 08-20-00

## LEVELING

### NOTE

**Level the aircraft only on even floor and in closed halls (wind protected).**

- 1 Secure each main wheel with two wheel chocks.

### WARNING

**Do not lift tail wheel higher than necessary for leveling. The aircraft may tilt onto the nose.**

### CAUTION

**Prior to levelling, ensure aircraft is clear of obstructions.**

- 2 Lift tail and put the jack (height: ~90 cm (~3 ft)) under the tail wheel, which has to be in the rearmost position.
- 3 Level the aircraft to its horizontal reference line using a spirit level (2), which is to put under the bolts of the rear main fuselage cover (1, Figure 1). Adjust pitch by changing the jack height.

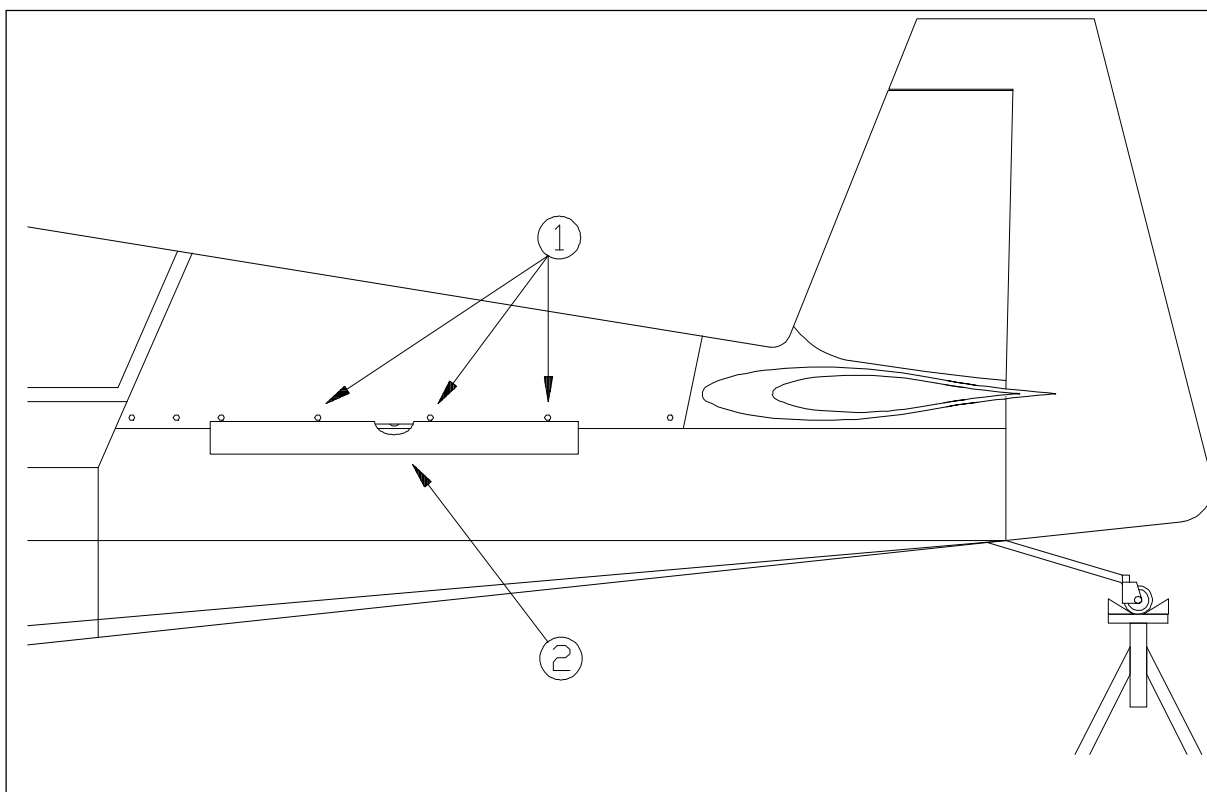

*Leveling  
Figure 1*